

SMOOV

NEW

SMOOV one O10



SMOOV

Electric drive unit for active wheelchairs

Highlights	3
Product advantages	4
Product setup	5
Scope of delivery	6
Bracket mounting	7
Technical data	8



MADE IN GERMANY ■■■

All highlights at a glance



Dynamically en route

- A version with a maximum assistance of 6 km/h and 10 km/h available
- Active, swift handling thanks to the swivelling drive wheel
- Tilted driving with docked on drive is possible
- Slope up to 16%



High range

- Range up to 20 km with one battery charging thanks to a highly efficient direct drive combined with state-of-the-art lithium ion technology



Lightweight

- Weighing just 7.2 kg, this is one of the lightest active drives on the market



Your „Low key“ companion

- Small, discreet drive unit under the wheelchair
- Modern, unobtrusive design



Easy to handle

- Intuitive docking and undocking of the drive and control unit
- Easy to use thanks to the ergonomic, wireless control unit



Minimum adjustments to your wheelchair

- Small, discreet bracket for the drive and control unit
- The wheelchair can still be used manually



Individually adaptable

- Personal settings and extension of the scope of functions possible via the SMOOV Mobility App

Product advantages

The SMOOV one is an electric power assist drive unit for active wheelchairs which significantly increases the driver's mobility and flexibility.

The key benefits at a glance

- Discreet, unobtrusive design
- Swivelling drive wheel for dynamic driving
- Extremely swift, turns itself on the spot
- Efficient, high-performance drive unit
- Tilted driving is also possible with the SMOOV one
- Intuitive docking and undocking of the drive unit and control unit
- Easy to use, thanks to the ergonomic, wireless control unit
- Individual adjustment and extension of the scope of functions possible via the SMOOV Mobility App
- Can be mounted to most active rigid-frame and folding wheelchairs

Wheelchair mounting

The SMOOV one was designed to be combined with rigid-frame wheelchairs. For this purpose, a small bracket must be fitted to the wheelchair crossbar. This is available for all current tube diameters. To attach the SMOOV one to folding wheelchairs, an optional adapter axle is required. This is fitted between the stub axles. The SMOOV one can be combined with folding wheelchairs with a wheel camber of up to 2°.

Compatibility check

Determine the following to ensure that the existing wheelchair can be combined with the SMOOV one: wheelchair manufacturer, exact model name, seat width and seat height in the case of rigid-frame wheelchairs. In the case of folding wheelchairs, the measure between the stub axles (measured internally) is necessary.

Contact our customer service with these details by calling 800-668-5324 (toll-free) or by e-mail at canadaorders@invacare.com

Our quality claim – Your safety

Seal of approval
and testing institute



TÜV Süd, Hanover

CE conformity



Complies with the EU
Medical Device Directive 93/42/EEC

Drive unit



Control unit





Drive unit

- Unobtrusive, high-quality design
- Robust, rustproof housing and rustproof fork
- Integrated lithium ion battery pack for a range up to 20 km
- High-performance drive for a maximum speed of up to 6 km/h, optionally of up to 6 km/h or 10 km/h with the upgrade via the Mobility app
- On/Off button and remaining capacity and operating mode display
- Ergonomic carrying handle
- Magnetic charger socket
- USB-C socket to charge the control unit or a smartphone



Control unit

- Large, ergonomic speed selection and On/Off knob
- Integrated LED display for operating status and remaining capacity of drive unit and control unit
- Integrated lithium ion battery cell for an operating time of approx. 20 hours



Battery charger

- Handy, compact charger
- Automatic charging and switch-off mechanism
- Multi-range charger 100-240 V, 50-60 Hz
- Charging time of an empty battery approx. 6 hours



Charging cable

- To charge the control unit from the drive unit
- USB-C to USB-C cable
- Length approx. 0.5 m



Mobility app

- The smart extension for the SMOOV one
- For smartphones running on the Android or iOS operating system
- Download from Google Play or App Store

An overview of the free functions

- Cockpit: shows the remaining capacity, speed, range and drive modes
- Tour: to record, save and manage trips
- Settings: for drive unit, control unit and app adjustments
- Diagnosis: information on warnings and fault indications
- Info: details and further information on the product and app

Optional functions for upgrading the SMOOV one

- Speed: this function increases the maximum speed from 6 km/h to 10 km/h
- Navigation: this function enables start/destination navigation with wheelchair accessible routing, speech output and offline map material
- Performance: this function enables the speed to be set, regardless of the turning angle of the drive wheel
- AutoSpeed: this function enables acceleration to a previously defined speed by a turn on the control unit



SMOOV Mobility app:
available in the Google Playstore
and App Store.



BRACKET MOUNTING

Wheelchair installation kit

- Mechanical connection of the SMOOV one to the manual active wheelchair (please include in order if not present)
- Can be mounted on most active wheelchairs with a fixed crossbar/camber tube (rigid-frame wheelchairs)
- Consists of a crossbar/camber tube bracket set and control unit bracket set

Adapter axle

- Optional axle to combine SMOOV one with most folding wheelchairs - The adapter axle is fitted between the stub axles; only compatible with wheelchairs with a wheel camber of 0° to 2°
- The length of the axle depends on the measure of the stub axle from left to right, measured internally
- The adapter axle can be easily fitted and removed so that the wheelchair can still be folded



Crossbar/camber
tube bracket set



Control unit
bracket set



Adapter axle

General*

Max. User weight	Max. 140 kg (300lb)
Total weight capacity	Max. 370 kg
Max. Climbability	Up to 16% (6°)

Drive unit

Motor power rating	250 W
Max. motor power	450 W
Operating voltage	36 V
Speed	0–10 km/h (optionally up to 6 km/h)

Battery pack (drive unit)

Battery cells	36 V; 6.2 Ah Lithium ion cells, leakproof and maintenance-free 24 months
Battery power	224 Wh
Range	Safe for air transportation according to IATA Up to 20 km, depending on the ground surface, the weight of the person, temperature and terrain

Battery charger

Input voltage	100–240 V
Frequency range	50–60 Hz
Output voltage	48 V (DC)
Charging current	1 A
Charging time	Approx. 6 hours

Weight

Product Weight	7.2 kg (16lb)
Control unit	250 g
Battery charger	500 g
Control unit bracket	Approx. 100 g**
Crossbar/camber tube bracket	Approx. 230 g**



EC compliant according to the
Medical Device Directive 93/42/EEC

Dimensions

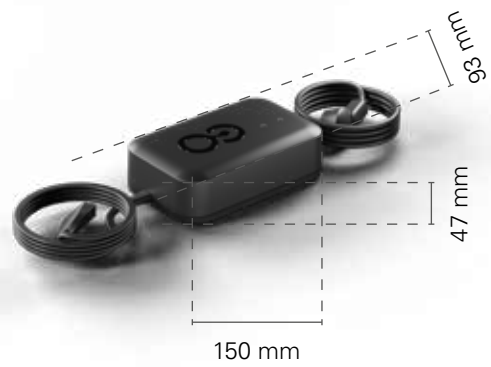
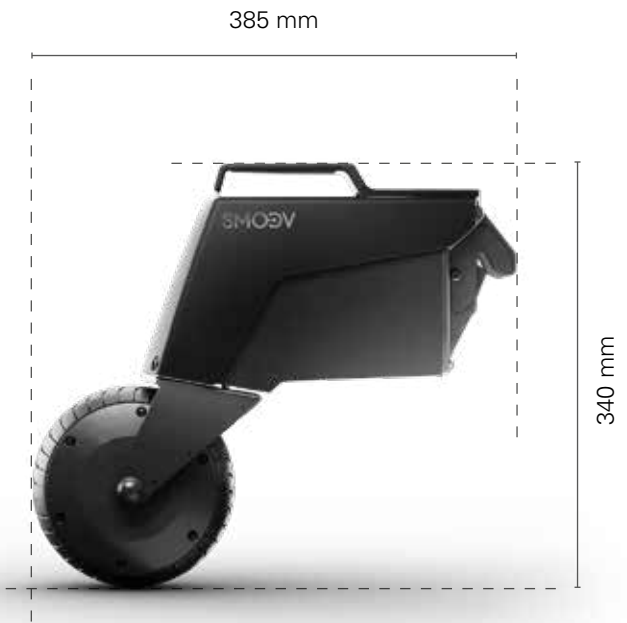

SMOOV one. Get your smooov on.



Invacare Canada LP
www.invacare.ca
570 Matheson Blvd. E.
Unit 8
Mississauga, Ontario
L4Z 4G4 Canada
(800) 668-5324

©2020
All rights reserved.
Trademarks are identified
by the symbols TM, SM
and ®. All trademarks are
owned by or licensed to
Invacare Corporation
unless otherwise noted.
Specifications are subject
to change without
notification.

Form No. 20-119C